

LXD EMERGENCY LIGHTING DOWNLIGHT SINGLE LED



Product description

The emergency lighting LXD consists of an LED lamphead with integrated battery, status display LED and an emergency lighting unit to operate the single LED in maintained and non-maintained mode. The safety-compliant downlight emergency lighting is for recessed mounting and ensures emergency escape route and anti-panic lighting in buildings. The integrated selftest function corresponds the European standard.

- Self-contained downlight - emergency luminaire
- Single LED luminaire with integrated battery, status display LED and connected emergency lighting driver
- High-quality aluminium PCB (powder-coated)
- Polycarbonate case for projection class I and II (L 205 x W 37 x H 21,75 mm)
- 5 years warranty

Properties

- Non-maintained and maintained mode
- Night light option (R - reverse dimmed maintained mode)
- Monitoring options available
- Different lenses for emergency escape route lighting (elliptical) and anti-panic lighting (rotationally symmetric) and for power-LED protection
- Simple recessed mounting of preinstalled luminaire and driver
- Strain relief
- 1 h, 3 h or 8 h operating time
- Selftest as per IEC 62034
- Status display LED
- SELV (safety extra low voltage)
- Constant power output in emergency mode
- Adapted charge condition for NiMH or LiFePO₄ batteries
- Deep discharge protection
- 30 % higher expected NiMH battery life duration by micro-processor controlled cycling charging

Technical specifications

Mains voltage range	220 V – 240 V
Mains frequency	50 / 60 Hz
Power consumption / power input standby	max. 2,4 W / 3 VA
Power output in emergency mode	3 W
Power consumption / power input standby	max. 5 W / 7 VA
Switchover time mains - emergency	< 0,5 s
Max. case temperature tc	65° C
Ambient temperature range ta	5° C – 50° C
Functionality test	weekly 2 min (random – see datasheet selftest)
Duration test	annually
Battery charging time	24 h
Protection class	I and II
Protection type	IP20
Weight	110 g + battery
Dimensions Y-case	L 205 x W 37 x H 21,75 mm
Diameter lamphead	48 mm
LED light efficiency	120 lm – 140 lm
LED colour	5300 K – 6000 K

Y-Case

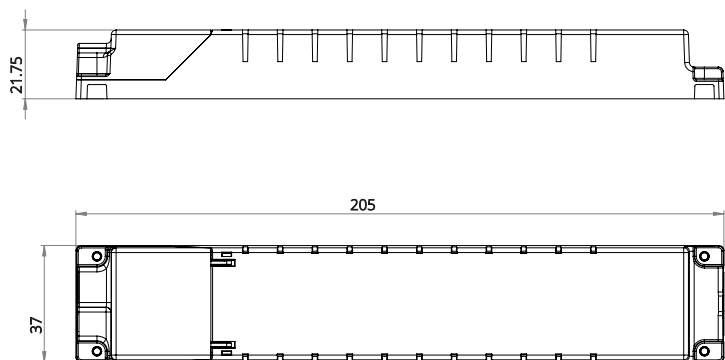

Single-LED

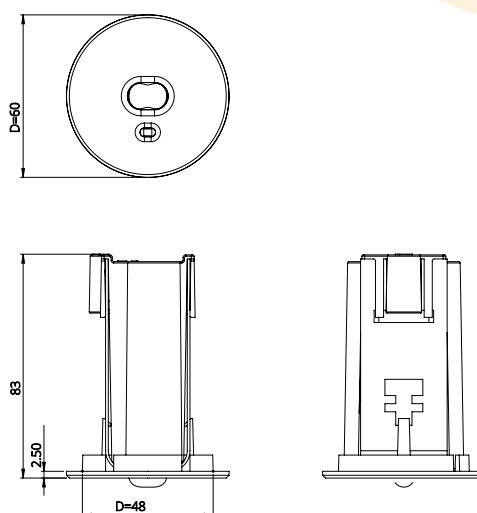

Technical Data

Specifications	Type	LXD non-maintained operation	LXD maintained and non-maintained operation	LXD BUS or DALI
Options		Selftest (S)	Selftest (S) Reverse (R) (dimmed maintained mode)	Selftest (S) Reverse (R) (dimmed maintained mode)
Operating time *		1 h 3 h	1 h 3 h 8 h	1 h 3 h 8 h
LED-current under mains operation		-	450 mA 150 mA (R)	450 mA 150 mA (R)
LED-current under emergency operation (depending on battery)		450 mA (1h) 200 or 450 mA (3h)	450 mA (1h) 200 or 450 mA (3h) 150 mA (8h)	450 mA (1h) 200 or 450 mA (3h) 150 mA (8h)
Lumen output in emergency mode* (depending on battery)		75 lm (1 h, 3 h) 150 lm (3 h)	50 lm (8 h) 150 lm (1 h, 3 h)	50 lm (8 h) 150 lm (1 h, 3 h)
Lumenoutput in reverse mode (R)		-	50 lm	50 lm
Battery (1-2 cells)		NiMH (LA-cells) LiFePO ₄ (18650-cells)	NiMH (LA-cells) LiFePO ₄ (18650-cells)	NiMH (LA-cells) LiFePO ₄ (18650-cells)
Power LED voltage		SELV (safety extra low voltage)	SELV (safety extra low voltage)	SELV (safety extra low voltage)
Escape route lighting		elliptical lens	elliptical lens	elliptical lens
Luminaire spacing in escape route lighting		75 lm = 6 m 150 lm = 12 m	50 lm = 4 m 150 lm = 12 m	50 lm = 4 m 150 lm = 12 m
Anti-panic lighting		rotationally symmetric lens	rotationally symmetric lens	rotationally symmetric lens

Selftest

- Selftest as per IEC 62034
- Two-coloured status display LED
- Status of battery
- Status of LED module

Visual status indication

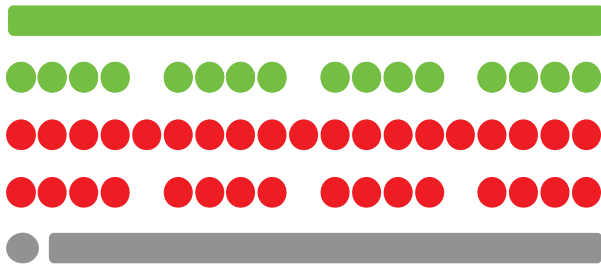

permanent green	= no fault
intermittently flashing green	= commissioning phase
continuously flashing red	= faulty battery
intermittently flashing red	= faulty lamp
dark	= faulty unit

Luminaires containing emergency lighting units with automatic selftest require a regular visual inspection of the status indicator (LED) and the fitting.

LED green: no fault / normal state

LED intermittently flashing green: The unit is in the commissioning phase. The unit will carry out several full discharge cycles during the first 8 days.

LED continuously flashing red: battery fault by either insufficient battery capacity or interrupted connection. The alarm is reset once the fault is cleared.

LED intermittently flashing red: lamp fault. Please note that the fault is not indicated (or reset) immediately when it occurs (or is cleared), but after the next selftest.

LED dark (LED off): if the LED is still off for more than 5 minutes after switching on the mains, then the mains or the unit is faulty.

Batteries

- High-temperature cells 5° C – 50° C
- NiMH- / LiFePO₄-batteries
- LA- / 18650-cells
- Specific capacities according to operating time
- Charging time 24 h
- 4 years expected life duration (>6 years LiFePO₄)
- 1 year warranty (2 years for LiFePO₄)
- Battery regeneration for capacity optimisation

Safety

- Protection class I and II
- Protection type IP20
- SELV
- Lens for power LED protection
- Double isolation between mains and LED output
- LED-output voltage is a SELV-voltage

Certification mark

- CE



Standards

- As per EN 60598-2-22
- EN 61347-2-7
- EN 61347-2-13
- EN 62034
- EN 55015
- EN 61000-3-2
- EN 61000-3-3
- EN 61547
- Suitable for systems according to: VDE 0108 or EN 50172

Photometric data

Available in LDT-format on request.

Mounting

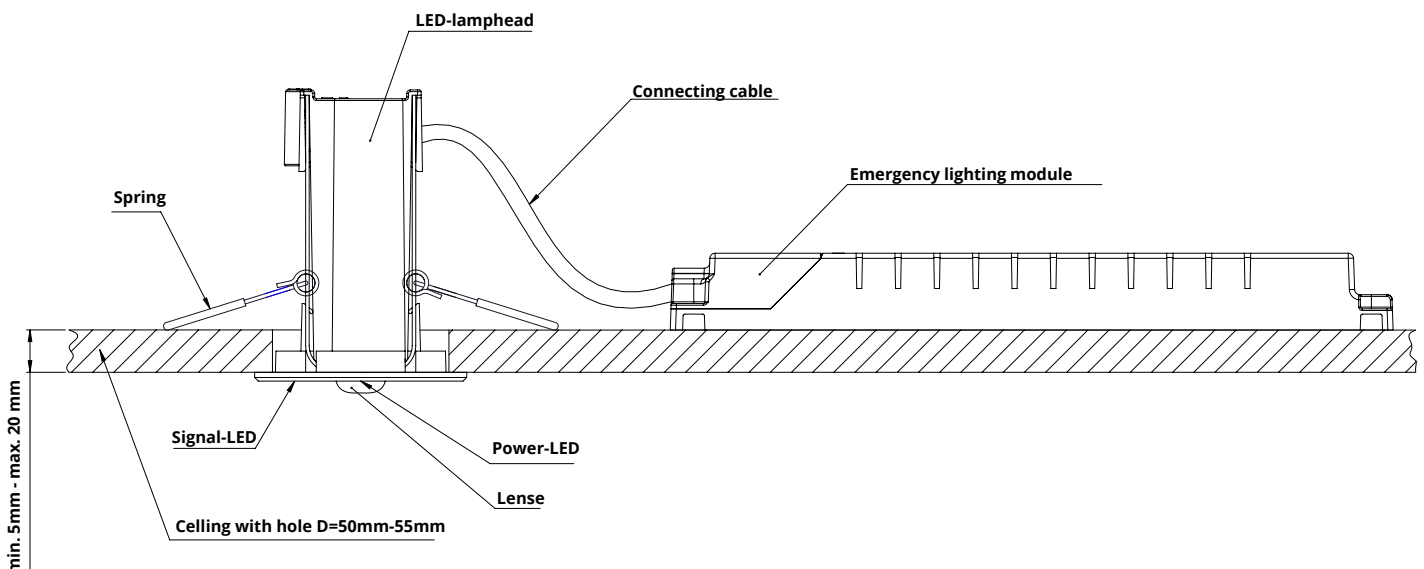

All information is supplied without liability. Technical data subject to change without notice. Errors and omission excepted.